

## Válečkovací nástroje | Slepé otvory

Série T | Rozsah průměrů: 127,90 mm - 149,90 mm (5,0354 - 5,9016")

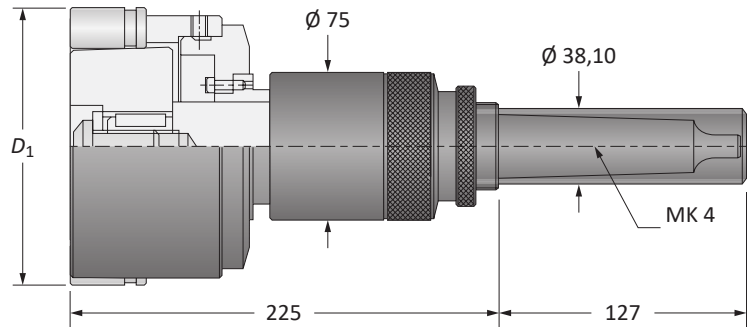

## Slepé otvory

$D_1$		Obj. číslo*		Náhradní součásti			
Metrické (mm)	Palcové (inch)	Sestava s kuželovou stopkou	Sestava s válcovou stopkou	Klec	Kužel**	Válečky	Počet válečků
127,90 - 128,90	5,0354 - 5,0748	RSKT-200-xxxxx	RSKT-100-xxxxx	RSCT-015-01280	RSTT-0xx-01280	RSRY-708-00812	11
128,90 - 129,90	5,0748 - 5,1142	RSKT-200-xxxxx	RSKT-100-xxxxx	RSCT-015-01290	RSTT-0xx-01290	RSRY-708-00812	11
129,90 - 130,90	5,1142 - 5,1535	RSKT-200-xxxxx	RSKT-100-xxxxx	RSCT-015-01300	RSTT-0xx-01300	RSRY-708-00812	11
130,90 - 131,90	5,1535 - 5,1929	RSKT-200-xxxxx	RSKT-100-xxxxx	RSCT-015-01310	RSTT-0xx-01310	RSRY-708-00812	11
131,90 - 132,90	5,1929 - 5,2323	RSKT-200-xxxxx	RSKT-100-xxxxx	RSCT-015-01320	RSTT-0xx-01320	RSRY-708-00812	11
132,90 - 133,90	5,2323 - 5,2717	RSKT-200-xxxxx	RSKT-100-xxxxx	RSCT-015-01330	RSTT-0xx-01330	RSRY-708-00812	11
133,90 - 134,90	5,2717 - 5,3110	RSKT-200-xxxxx	RSKT-100-xxxxx	RSCT-015-01340	RSTT-0xx-01340	RSRY-708-00812	11
134,90 - 135,90	5,3110 - 5,3504	RSKT-200-xxxxx	RSKT-100-xxxxx	RSCT-015-01350	RSTT-0xx-01350	RSRY-708-00812	11
135,90 - 136,90	5,3504 - 5,3898	RSKT-200-xxxxx	RSKT-100-xxxxx	RSCT-015-01360	RSTT-0xx-01360	RSRY-708-00812	11
136,90 - 137,90	5,3898 - 5,4291	RSKT-200-xxxxx	RSKT-100-xxxxx	RSCT-015-01370	RSTT-0xx-01370	RSRY-708-00812	11
137,90 - 138,90	5,4291 - 5,4685	RSKT-200-xxxxx	RSKT-100-xxxxx	RSCT-015-01380	RSTT-0xx-01380	RSRY-708-00812	11
138,90 - 139,90	5,4685 - 5,5079	RSKT-200-xxxxx	RSKT-100-xxxxx	RSCT-015-01390	RSTT-0xx-01390	RSRY-708-00812	11
139,90 - 140,90	5,5079 - 5,5472	RSKT-200-xxxxx	RSKT-100-xxxxx	RSCT-015-01400	RSTT-0xx-01400	RSRY-708-00812	11
140,90 - 141,90	5,5472 - 5,5866	RSKT-200-xxxxx	RSKT-100-xxxxx	RSCT-015-01410	RSTT-0xx-01410	RSRY-708-00812	11
141,60 - 142,90	5,5866 - 5,6260	RSKT-200-xxxxx	RSKT-100-xxxxx	RSCT-015-01420	RSTT-0xx-01420	RSRY-708-00812	11
142,90 - 143,90	5,6260 - 5,6654	RSKT-200-xxxxx	RSKT-100-xxxxx	RSCT-015-01430	RSTT-0xx-01430	RSRY-708-00812	11
143,90 - 144,90	5,6654 - 5,7047	RSKT-200-xxxxx	RSKT-100-xxxxx	RSCT-015-01440	RSTT-0xx-01440	RSRY-708-00812	11
144,90 - 145,90	5,7047 - 5,7441	RSKT-200-xxxxx	RSKT-100-xxxxx	RSCT-015-01450	RSTT-0xx-01450	RSRY-708-00812	11
145,90 - 146,90	5,7441 - 5,7835	RSKT-200-xxxxx	RSKT-100-xxxxx	RSCT-015-01460	RSTT-0xx-01460	RSRY-708-00812	11
146,90 - 147,90	5,7835 - 5,8228	RSKT-200-xxxxx	RSKT-100-xxxxx	RSCT-015-01470	RSTT-0xx-01470	RSRY-708-00812	11
147,90 - 148,90	5,8228 - 5,8622	RSKT-200-xxxxx	RSKT-100-xxxxx	RSCT-015-01480	RSTT-0xx-01480	RSRY-708-00812	11
148,90 - 149,90	5,8622 - 5,9016	RSKT-200-xxxxx	RSKT-100-xxxxx	RSCT-015-01490	RSTT-0xx-01490	RSRY-708-00812	11

\*xxxxx = Odkaz na válečkovanou velikost s přesností na 2 desetinná místa (např. válečkovací nástroj  $\varnothing$  140,00 mm s válcovou stopkou: RSKT-100-14000).

\*\*x = Číslo v rozsahu 2-8. Závisí na přesném válečkováném průměru. Správný postup pro určení hodnoty „x“ naleznete na straně D: 6.

**POZNÁMKA:** Válečkovací nástroje se dodávají kompletní, včetně klece, kužele a válečků.

D: 42 - 45

D: 40 - 41

D: 39

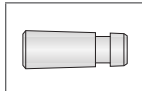
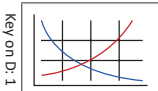

Key on D: 1